

# CORE & CORE MAX

High efficiency water/water and geothermal heat pumps 28÷114



## General

High efficiency water/water and geothermal heat pumps. Ideal for heating, cooling and production of domestic hot-water with total or partial recovery.

## Configurations

CH: Reversible, cooling only

HWS: Heat exchanger for hot tap water

DS: Desuperheater

LN: Low sound level

Optional pump

## Quick facts

- ▶ Eco-friendly cooling
- ▶ High EER
- ▶ Patented innovation
- ▶ Efficient energy performance
- ▶ Advanced software
- ▶ Years of dependability

## INDEX

TECHNICAL FEATURES	3
SYSTEM LAYOUT	8
CORE & CORE MAX - technical data	10
CORE & CORE MAX - dimensions and operating limits	13
CORE & CORE MAX - electrical data	14
CORE & CORE MAX - pump diagrams	15
CORE & CORE MAX - heat exchangers diagram	16
CORE & CORE MAX - ecodesign	18
DIMENSIONAL DRAWING	19
INSTALLATIONS RECOMMENDATIONS LOCATION	25

## TECHNICAL FEATURES

### CORE and CORE MAX

The CORE series has a unique design. Ideal for heating, cooling and production of domestic hot water with total or partial recovery, the CORE series has been designed to achieve the maximum from the available energy. The technical solutions and the implemented control logic make this innovative series reliable and of high performance. The energy efficiency values are among the highest on the market today. The series consists of 11 configurations, from 28 to 114 kW.

Ideal for using with:

- Vertical geothermal probes
- Horizontal geothermal probes
- Well water
- Tower water

### STRUCTURE

Structure in steel sheet coated with RAL 9003 epoxy-polyester powder paint, with removable panels on the three sides to facilitate the access for maintenance and installation operations.

The electrical and hydronic connections and the access to the temperature probe are in the upper part of the unit in order to allow installation on the wall. The units are designed to be installed from inside. The unit is always supplied with rubber antivibration mounts. Moreover, the unit base bears, via antivibration mounts, a structure that collects all moving components (pumps and compressors) and the compressors are also supported by antivibration mounts. This three-way absorbing system ensures complete obstruction of vibrations transmission to the floor.

### COMPRESSOR

The compressors are hermetically sealed scroll type, specially designed to be used in high efficiency heat pumps for the production of high temperature water.

Each compressor is equipped with thermal breaker, oil level gauge, crankcase heater and rubber antivibration mounts to reduce the vibration transmission to the unit.

### COOLING CIRCUIT

Comprises: scroll compressors, plate heat exchanger on the source side, loading plugs for maintenance, dehydrating filter, thermostatic expansion valve, high and low pressure switches. The unit can also comprise, depending on the outfit, a plate heat exchanger for domestic hot water production, a second thermostatic valve or a single electronic thermostatic valve and 4-way valve for cycle switching.

### PLATE HEAT EXCHANGER ON THE SOURCE AND USER SIDE

The brazed plate heat exchangers are made in stainless steel AISI 316 and insulated against condensate, ideal for reducing thermal losses. The heat exchangers are equipped with temperature probe for antifreeze protection. The accurate selection of the heat exchangers has allowed the enhancement of operation performance in heat pump mode and extremely reduced pressure drop even at high concentrations of glycol. This way the unit pumps operate with minimum power con-

sumption.

### HYDRAULIC CIRCUIT

Depending on the outfit and accessories, the unit may be equipped with: flow switches installed inside the unit, already connected to the control device, source side connections, user and domestic water side (if fitted with the special heat exchanger) connected via flexible pipes (supplied with the unit, accessory). These type of connections allow the reduction of the vibration transmitted to the plant pipes.

### ELECTRICAL PANEL

The electric panel on the upper part of the unit has been designed to guarantee maximum accessibility and consists of:

- Main disconnect switch (only for models from 43 to 111)
- Automatic disconnect switch for the main and auxiliary power circuit protection
- Compressor remote disconnect switch
- Microprocessor control for full control of unit parameters

All wires are numbered to facilitate maintenance and the reading of the electric diagram.

The regulation systems depend on the unit outfit and comprise:

- Regulation of user temperature set-point in winter mode
- Circulation/pump control on source side
- Circulation/pump control on user side
- Set-point variation depending on the external temperature (accessory)
- Remote terminal or user interface display (accessory)
- Antifreeze protection for the heat exchanger on the source side
- Low water flow protection on the source side
- Compressor timing
- Alarm signalig
- ON/OFF digital input

The HP basic outfit versions (reverse heat pump) are further fitted with:

- Regulation of user temperature set-point in summer mode
- Antifreeze protection for the heat exchanger on the plant side
- Low water flow protection for the heat exchanger on the plant side
- Control of the 4-way valve for cycle switching

The HWS (Hot Water Solution) versions, besides the HP outfit, are equipped with:

- Regulation of domestic hot water temperature set-point
- Regulation of domestic hot water temperature set-point in total recovery mode
- Circulation/pump control on the source side
- Circulation/pump control on domestic hot water side
- Automatic control of cycle switching for heat recovery or for prior production of domestic hot water
- Control of the last 100 alarm record entries

## CONTROL AND SAFETY DEVICES

All units are equipped with the following control and safety devices:

- Manual reset high pressure switch;
- Low pressure switch with manual reset at the third alarm;
- High pressure safety valve;
- Water temperature control probe on the plant side;
- Antifreeze probe on heat exchangers outlet (one or two, depending on the outfit);
- Vane mechanical flow switch fitted or connected (one or two, depending on the outfit);
- Compressor overtemperature protection.

## TESTING

All units are factory-tested and supplied complete with oil and refrigerant.

## OUTFITS

### Basic:

#### non reversible heat pump

##### /HP:

reversible heat pumpThe unit can operate as a heat pump or as a chiller and the cycle can be switched directly from the unit control.

Beside the basic version components, the unit comprises

- 4-way inversion valve
- flow switch for the heat exchanger on the plant side
- additional mechanical thermostatic valve

##### /HWS:

#### multifunctional heat pump

This outfit comprises three heat exchangers: one on the source side, one on the plant side and one on domestic water side. On the plant side heat exchanger, the unit can produce both hot and cooled water, depending on the season, to meet the heating or cooling needs of the building. On the domestic water heat exchanger, the unit produces water of high temperature to be conveyed to a storage tank outside the unit. The unit operates differently, depending on the season: automatic switching from one operation mode to another (during the season) depending on the temperature probes and set-point reading. Timing and logic of switching are set to guarantee maximum efficiency and reliability of the system.

### THERE ARE 3 SUMMER OPERATING MODES:

1. Chiller mode: the unit provides the production of cooled water for the system.
2. Production of domestic hot water and chiller mode at the same time: the unit produces cooled water for the system and domestic hot water at the same time. The capacity recovered for the production of domestic hot water can be total or partial, depending on the needs and storage tank.
3. Production of domestic hot water only: when there is no cooling load, the unit provides the heating of the water inside the storage tank for domestic use (outside the unit),

using the second exchanger as an evaporator. The use of water as a heat source ensures reaching of extremely high COP.

THERE ARE 2 WINTER OPERATING MODES:

1. Heat pump mode for heating: the unit provides the heating of water in the plant until it reaches the set temperature
2. Heat pump mode for the production of domestic hot water: the unit provides the heating of the domestic hot water at high temperature. The switching from mode 1 to mode 2 is entirely automatic, following a logic of priority to produce domestic hot water.

Besides the HP version components, the unit comprises:

- heat exchanger for the production of domestic hot water
- temperature probe to be installed on the domestic hot water storage tank
- double flow electronic thermostat valve (replacing the two mechanical thermostatic valves)
- programmable microprocessor control (replaces the parameters setting control)

##### /LN:

#### low-noise outfit

Can be combined with any of the aforementioned versions, insulated inside by means of panels made of sound absorbing material and high impedance material for further lowering of noise emission. The material is made of two layers of sound absorbing material and one layer of high impedance material able to substantially obstruct the noise emissions of frequencies between 100 and 8000 Hz.

## HYDRAULIC SYSTEM OPTIONS

The basic version has no circulation device or pump fitted. Upon request, the unit can be combined with any of the following hydraulic modules:

##### /ST 1P

#### pump on the plant side:

the unit is equipped with a circulation device or a pump (depending on the model) on the plant side hydraulic circuit, a discharge valve for hydraulic circuit water, a safety valve calibrated at 6 bar that corresponds to the maximum allowed operating pressure.

##### /1S

#### pump on the source side:

the unit is equipped with a circulation device or a pump (depending on the model) on the source side hydraulic circuit, a discharge valve for hydraulic circuit water.

##### /1R

#### pump on the domestic water side:

the unit is equipped with a circulation device or a pump (depending on the model) on the domestic water side hydraulic circuit, a discharge valve for hydraulic circuit water. This hydraulic module can be fitted only on the HWS version units

## STANDARD EQUIPMENT

- Rubber antivibration mounts
- Installed flow switch source side
- Installed flow switch plant side
- Remote On/Off control digital input
- Power and auxiliary circuits protection
- Voltage free contact for source side pump managing
- Voltage free contact for user side pump managing
- Voltage free contact for recovery side pump managing

## ACCESSORIES

### HYDRAULIC CIRCUIT ACCESSORIES

- Water filters kit
- Flexible pipes kit for hydronic connection
- Automatic filling kit with pressure gauge
- Expansion vessel (plant side)
- Expansion vessel (source side)
- Expansion vessel (domestic hot water side)
- Water safety valve
- Condensing control with pressure control valve for well water
- Condensing control with variable flow pump at source side

### ELECTRICAL ACCESSORIES

- Phase monitor
- RS485 serial interface
- Single voltage-free operating contacts
- Remote control terminal
- Electronic soft-starter

### VARIOUS ACCESSORIES

- Pressure gauges
- Packing in wooden crate

#### Automatic management of domestic hot water

This accessory allows the unit to control the temperature inside the storage tank for domestic hot water through a special probe, and to manage the production by following a priority logic.

The heat pump normally operates on the system to meet the comfort requirements of the building, but when the water temperature inside the tank lowers under the set threshold, the control manages the domestic water production: if the unit operates as heat pump for heating, the 3-way valve is switched over and the set point modified. Otherwise, if the unit is producing cooled water for the air conditioning, the control switches it over in heat pump mode, it assigns the correct set point for the DHW and turns the 3-way valve to the appropriate position.

Once the temperature inside the domestic water tank has reached the set value, the unit turns automatically to the water production for the heating system and the air conditioning.

The accessory includes the temperature probe to place in the domestic hot water tank and the terminal board contacts for controlling an external 3-way valve (not included).

### Electronic thermostatic valve

The use of this accessory is particularly indicated for units that operate in very unstable heat load conditions or in unstable functional mode, as in the case of joint management of air conditioning and production of high temperature water. Use of the electronic thermostatic valve in fact allows to:

- maximise the heat exchange to the evaporator
- minimise response times on load variation and on operative conditions
- optimise the regulation of the over-heating
- guarantee maximum energy efficiency

### Self-adaptable regulation logic

This function allows the unit control to dynamically vary the outlet water set point according to the stop and functional cycles of the machine: in practice, by increasing and reducing the water outlet temperature, the control avoids that compressor start-ups are too close in time, decreasing the number of peaks and protecting the unit components

### Remote On/Off from digital input

This function is standard on all units and consists in a remote contact that allows to switch on and off the machine through a signal that can be taken inside the building by a BMS (Building Management System) system.

### Summer/winter selection from digital input

This function is standard on all heat pumps. When the unit is switched on, a functioning mode must be set, which can be either the heat pump or the chiller one. Through this remote contact, the functioning mode can be modified even inside the building and without a direct access to the microprocessor control.

Not available with HWS version.

### Filling system with manometer

This accessory allows the automatic load of the hydraulic system, the adjustment of the correct working pressure, which can always be verified by using the manometer, and enables the continuous maintenance of such pressure, reintegrating the missing water if necessary.

### RS-485 INTERFACE

The growing diffusion of both domestic and BMS (Building Management System) systems led to the integration of all the system components under an only supervision. To respond to this request, the unit can be equipped with a serial board that allows the correct machine integration in the "building-system", by using MODBUS or CAREL communication protocols.

### Remote control user terminal

Intended for a professional user, it consists in a faithful reproduction of the control panel, from where the unit can be completely set and all its parameters visualised on the display. Insertion of passwords, which enable different access levels, are required to access the parameters.

The type of terminal depends on the control installed on the unit

**μAD user interface**

By using a simple and intuitive interface, this device allows to carry out the following main functions:

- switching on and off the unit
- The unit function mode switch-over from heat pump to chiller and vice versa
- Enabling the sleep function
- The weekly timer thermostat function with automatic ON/OFF management of the unit
- Displaying unit functioning conditions

**SOFT-STARTER**

Blue Box units adopt all the required functioning set-ups and logics to minimise peak currents. The Soft-Starter accessory allows a further 40% reduction of normal current peaks, through an electronic control of the electric motor start-up.

**3-way valve**

It is an on/off three-way valve that combined with the “Automatic management of domestic hot water” accessory, allows the machine to manage two different circuits for the comfort and production of domestic hot water, switching over automatically from one to another, according to the system requirements.

**DOUBLE SET POINT**

The microprocessor enables you to set two set temperatures for the production of cold and hot water. Unless specified otherwise in the order, the default values are 12/7 °C and 15/10 °C for chiller mode and 40/45 °C and 35/40 °C for heat pump mode. The set temperatures must, in any case, remain within the operating ranges of the unit.

Use either the keypad or the digital input to switch between the first and second set. For series that do not permit the simultaneous selection of “Select summer/winter mode with digital input” and “Double set point with digital input”, summer/winter mode can be selected only on the keypad while the double set point still uses the digital input, as per our standard.

**Compensation of the set-point according to the external air temperature**

The unit microprocessor control can compensate the set point in a dynamic way, on variation of the external air temperature. The compensation can be positive or negative: with positive compensation, on increase of the air temperature the functioning set also increases. With negative compensation on increase of the air temperature the set decreases. Compensation can be made either on the summer set point or on the winter set point (heat pumps).

By default, both summer and winter negative compensation is set, but this configuration can be modified from the microprocessor keyboard. Unless otherwise specified, default values are indicated in the graphics below.

SUMMER COMPENSATION - POSITIVE

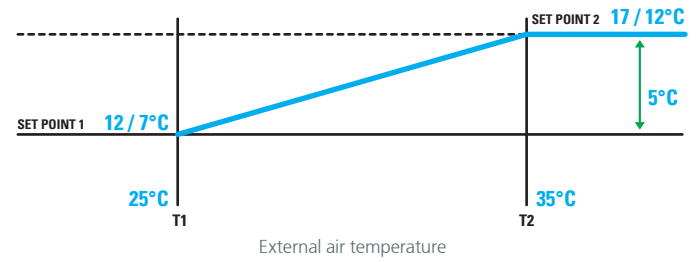

SUMMER COMPENSATION - NEGATIVE

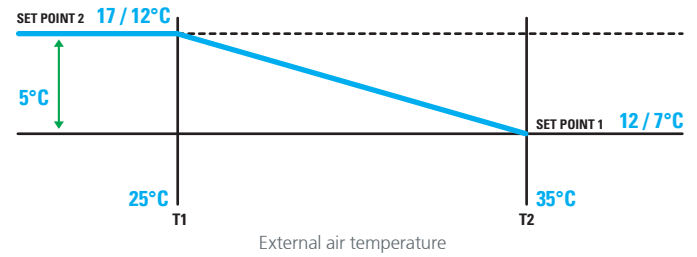

WINTER COMPENSATION - POSITIVE

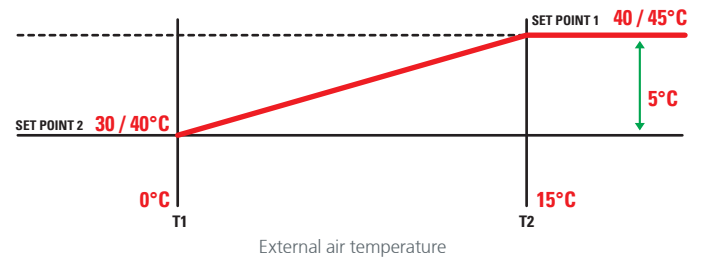

WINTER COMPENSATION - NEGATIVE

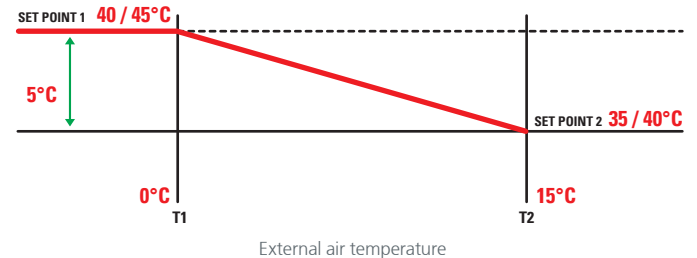

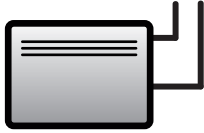

### HYDRONIC TERMINALS

They can be various types: fan coil, cassette or water air handling unit. In general they can be used for heating, cooling and dehumidification.

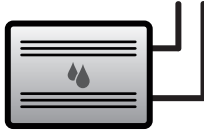

### WATER DEHUMIDIFIER

It can use the same water as the radiant panels system in summer functioning mode for pre/post handling of the air, thus obtaining isothermal dehumidification.



### RADIANT PANEL

It can be floor-standing or wall-hung and allows both heating and cooling of environments. The low temperatures of the water in winter functioning mode and the high temperatures in summer functioning mode allow to obtain very high energy efficiency, especially if coupled to the heat pump technology. In summer functioning mode it must be flanked by a dehumidification system.

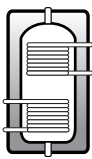

### STORAGE TANK FOR DOMESTIC HOT WATER

Dedicated to the accumulation or instant production of the domestic hot water. It can be of different types and dimensions and must be evaluated on the basis of the type of application and the necessary use in the building.

As well as the connections dedicated to the heat pump, it can also envision one or more integration systems via boiler, solar panels or electric resistors.

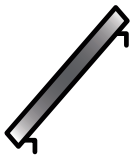

### SOLAR HEAT PANEL

It must be coupled with storage tank and act as integration for the production of domestic hot water that is normally entrusted to the heat pump.

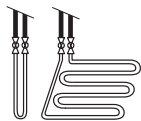

### GEO THERMIC PROBES

They can be horizontal or vertical and their dimension is determined by the designer depending on the power to be exchanged with the ground.

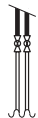

### WELL

This general symbol is used to indicated all heat sources that can work with disposable water and therefore water tables, watercourses or streams. This type of application is normally governed by local laws and could request the insertion of an intermediate exchanger (not represented in these layouts).

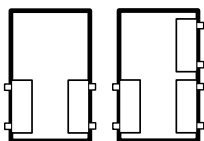

### WATER-WATER OR GEO THERMIC UNITS

To be installed internally, they require a water source or geothermic probe. The units in HWS set-up envision a further exchanger dedicated to the production of domestic hot water.

## SYSTEM LAYOUT

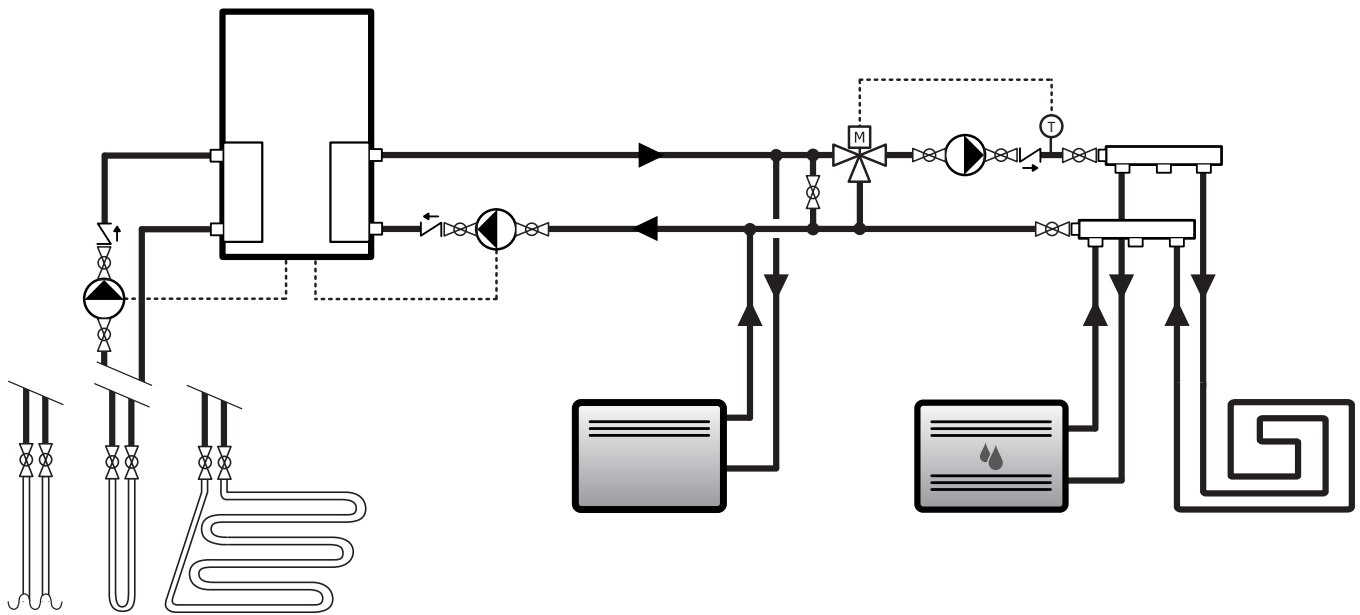

MIXED SYSTEM: the layout represents a typical application where in some rooms fan coils are used, while in others a radiant panel system and dehumidifier are used.

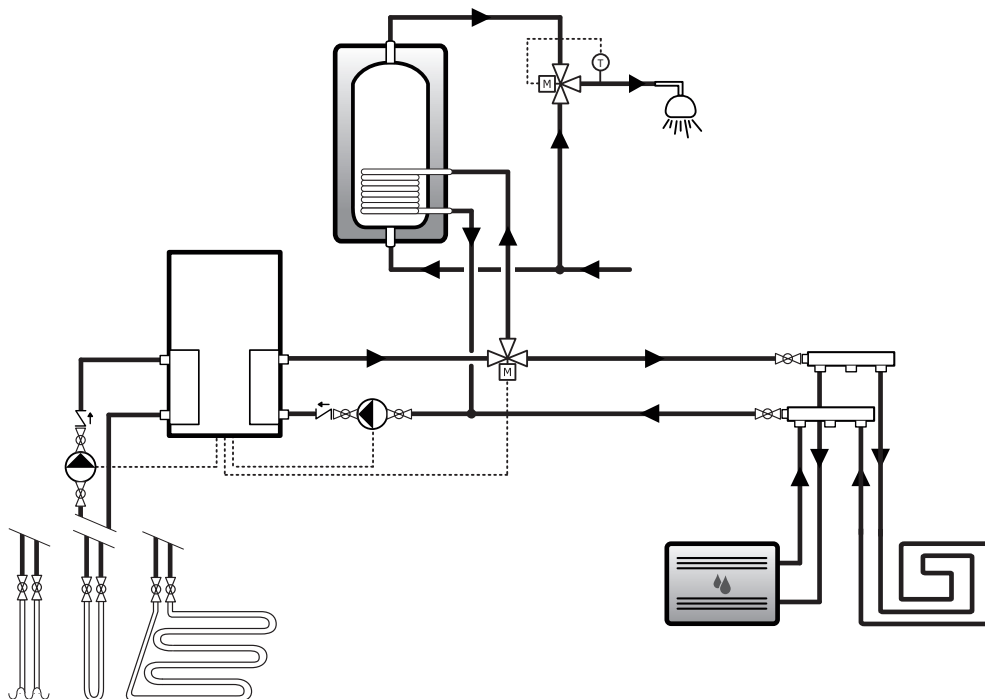

RADIANT PANELS SYSTEM WITH PRODUCTION OF DOMESTIC HOT WATER: in this type of system the heat pump manages winter heating and summer cooling and can also produce domestic hot water for a storage tank.



SYSTEM LAYOUT

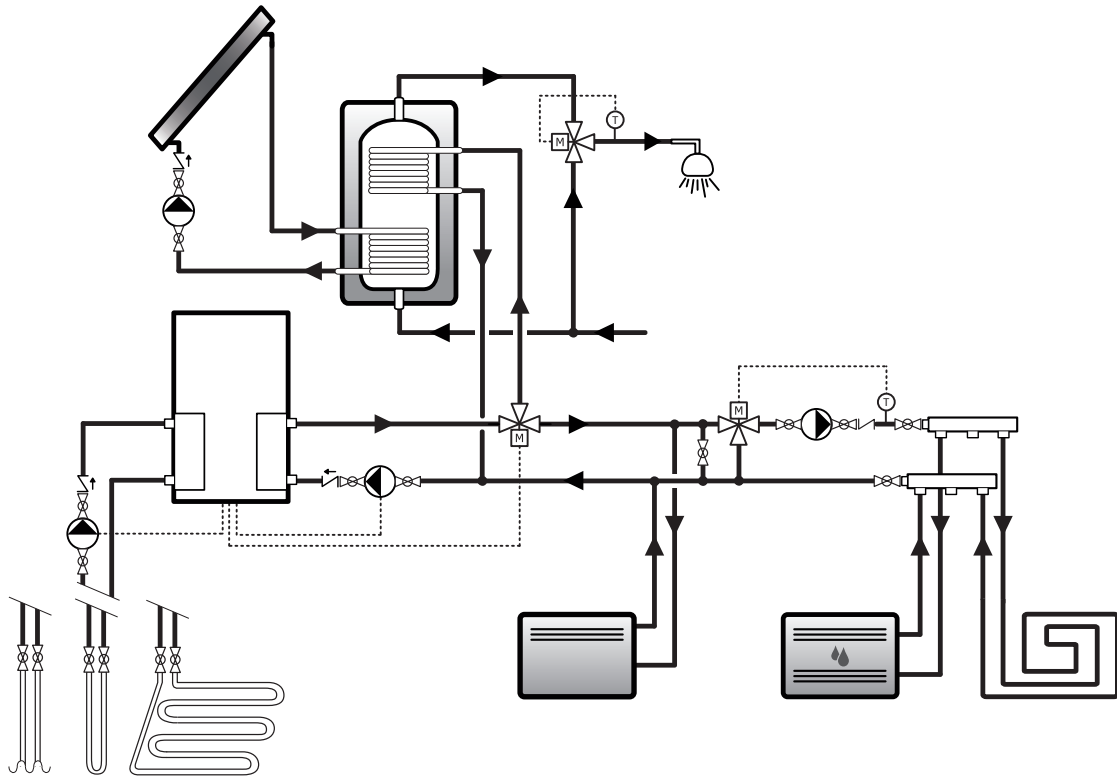

RADIATORS SYSTEM: as it can also produce water at high temperatures, the heat pump can also be used in radiator or mixed radiator fan coil systems. The insertion of a domestic hot water storage tank allows to completely eliminate the need of a boiler.

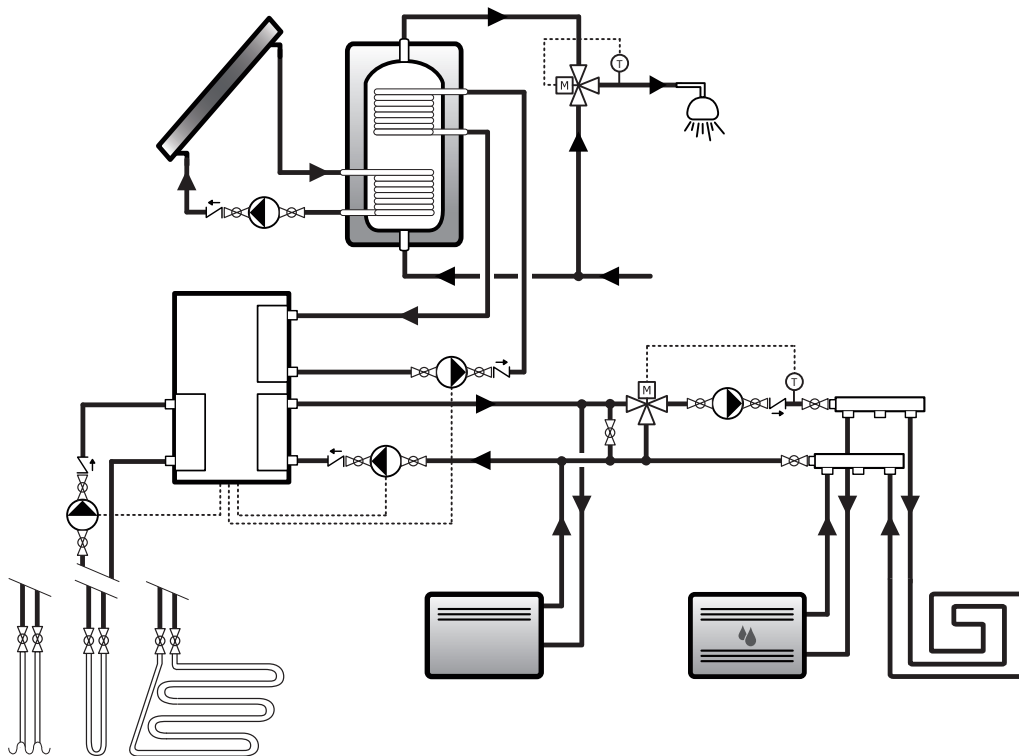

MIXED SYSTEM WITH PRODUCTION OF DOMESTIC HOT WATER WITH HWS SYSTEM: in summer functioning mode, the HWS (Hot Water Solution) system allows to produce domestic hot water free of charge every time the unit is producing cooled water for the air conditioning. The system can be integrated with the use of solar heat panels, or even better, with photovoltaic panels for the production of electrical energy for the power supply of the heat pump.

## CORE - TECHNICAL DATA

Unit size			27	32	37
<b>Cooling (Gross values)</b>					
Cooling capacity (W 30°C/W 18°C)	(4)	kW	31,7	37,1	43,2
Total power input for cooling	(1)(4)	kW	5,1	5,8	6,6
EER	(4)		6,24	6,4	6,58
Efficiency class			A	A	A
<b>Cooling (EN 14511 values)</b>					
Cooling capacity (W 30°C/W 18°C)	(4)(9)	kW	31,5	36,9	42,9
EER	(4)(9)		5,71	5,88	6,03
Efficiency class			A	A	A
<b>Cooling (Gross values)</b>					
Cooling capacity (W 30°C/W 7°C)	(5)	kW	22,1	25,2	30
Total power input for cooling	(1)(5)	kW	4,9	5,6	6,3
EER	(5)		4,54	4,52	4,8
Efficiency class			C	C	B
<b>Cooling (EN 14511 values)</b>					
Cooling capacity (W 30°C/W 7°C)	(5)(9)	kW	22	25,1	29,9
EER	(5)(9)		4,31	4,31	4,55
Efficiency class			C	C	C
ESEER			5,2	5,14	5,59
<b>Heating (Gross values)</b>					
Heating capacity (W 10°C/W 35°C)	(2)	kW	29,7	34,1	40,3
Power input	(1)(2)	kW	4,8	5,5	6,2
COP	(2)		6,17	6,17	6,52
Efficiency class			A	A	A
<b>Heating (EN 14511 values)</b>					
Heating capacity (W 10°C/W 35°C)	(2)(9)	kW	29,6	33,9	40,1
COP	(2)(9)		5,68	5,71	6,01
Efficiency class			A	A	A
<b>Heating (Gross values)</b>					
Heating capacity (W 10°C/W 45°C)	(3)	kW	28	32,2	37,9
Power input	(1)(3)		5,8	6,8	7,7
COP	(3)		4,79	4,75	4,95
Efficiency class			A	A	A
<b>Heating (EN 14511 values)</b>					
Heating capacity (W 10°C/W 45°C)	(3)(9)	kW	27,9	32	37,8
COP	(3)(9)		4,52	4,5	4,68
Efficiency class			A	A	A
<b>Compressor</b>					
Quantity/Cooling circuits		n°/n°	1/1	1/1	1/1
<b>Pump on the plant side</b>					
Pump head rating	(6)				
Pump head rating		kPa	44	32	88
Heat exchanger pressure drop	(4)	kPa	26	26	26
Heat exchanger pressure drop	(5)	kPa	23	23	22
Heat exchanger pressure drop	(2)	kPa	31	30	33
Heat exchanger pressure drop	(3)	kPa	18	16	19
<b>Pump on the source side</b>					
Pump head rating	(6)				
Pump head rating		kPa	138	108	46
Heat exchanger pressure drop	(4)	kPa	50	48	53
Heat exchanger pressure drop	(5)	kPa	40	39	43
Heat exchanger pressure drop	(2)	kPa	39	38	42
Heat exchanger pressure drop	(3)	kPa	23	21	24
<b>Noise levels</b>					
Noise power level	(7)	dB(A)	58	60	60
Noise pressure level	(8)	dB(A)	53	55	55

- (1) Total power absorbed by the compressors
- (2) Ambient water user side input-output 30/35 ° C, input-output water temperature source side 10/7 ° C
- (3) Temperature input-output water user side 40/45 ° C, input-output water temperature source side 10/7 ° C
- (4) Temperature input-output water user side 23/18 ° C temperature source side water inlet-outlet 30/35 ° C
- (5) Temperature input-output water user side 12/7 ° C temperature source side water inlet-outlet 30/35 ° C
- (6) If provided by the configuration
- (7) Noise power levels calculated according to ISO 3744, nominal conditions

- (8) Noise pressure levels measured at 1 meter from the unit in free field, with a directivity factor Q=4
- (9) Values according to EN 14511-3:2011

This data sheet gives the characteristic data of the basic and standard versions of the range; for more details please refer to the specific documentation. The values and images inside the document are indicative and can be modified by the manufacturer without prior notification. For further information refer to the specific documentation. The reproduction of this material, even partial, is prohibited.

## CORE MAX - TECHNICAL DATA

Unit size			43	50	55	63	74	84	95	111
<b>Cooling (Gross values)</b>										
Cooling capacity (W 30°C/W 18°C)	(4)	kW	46,8	55,2	58,4	68,6	81,9	94,7	105	115,6
Total power input for cooling	(1)(4)	kW	8,1	9,5	10,4	11,9	13,1	15	16,9	20,1
EER	(4)		5,79	5,83	5,62	5,77	6,26	6,33	6,22	5,76
Efficiency class			A	A	A	A	A	A	A	A
<b>Cooling (EN 14511 values)</b>										
Cooling capacity (W 30°C/W 18°C)	(4)(9)	kW	46,6	55	58,2	68,3	81,5	94,3	104,5	115
EER	(4)(9)		5,46	5,45	5,28	5,42	5,84	5,91	5,82	5,38
Efficiency class			A	A	A	A	A	A	A	A
<b>Cooling (Gross values)</b>										
Cooling capacity (W 30°C/W 7°C)	(5)	kW	32,7	37,7	41,9	48,5	57,3	65,6	73,1	84,9
Total power input for cooling	(1)(5)	kW	8	9	9,9	11,2	12,8	14,4	16,1	19,5
EER	(5)		4,07	4,2	4,23	4,34	4,49	4,54	4,53	4,35
Efficiency class										
<b>Cooling (EN 14511 values)</b>										
Cooling capacity (W 30°C/W 7°C)	(5)(9)	kW	32,6	37,6	41,8	48,3	57,1	65,4	72,8	84,6
EER	(5)(9)		3,93	4,04	4,07	4,18	4,31	4,37	4,36	4,17
Efficiency class			D	D	D	D	C	C	C	D
ESEER			5,35	5,31	5,38	5,51	5,53	5,65	5,6	5,65
<b>Heating (Gross values)</b>										
Heating capacity (W 10°C/W 35°C)	(2)	kW	46,2	53,5	58,4	68,1	80,2	91,3	102	119,4
Power input	(1)(2)	kW	7,9	8,8	9,7	10,9	12,4	14	15,8	19
COP	(2)		5,89	6,08	6	6,26	6,47	6,55	6,46	6,29
Efficiency class			A	A	A	A	A	A	A	A
<b>Heating (EN 14511 values)</b>										
Heating capacity (W 10°C/W 35°C)	(2)(9)	kW	46	53,2	58,1	67,8	79,8	90,9	101,6	118,9
COP	(2)(9)		5,58	5,71	5,65	5,89	6,07	6,14	6,08	5,88
Efficiency class			A	A	A	A	A	A	A	A
<b>Heating (Gross values)</b>										
Heating capacity (W 10°C/W 45°C)	(3)	kW	43,7	50,6	55	64,4	75,6	86,1	96	112,8
Power input	(1)(3)	kW	9,7	10,9	11,8	13,4	15,4	17,2	19,2	22,8
COP	(3)		4,51	4,65	4,66	4,82	4,92	5,02	5,01	4,94
Efficiency class			A	A	A	A	A	A	A	A
<b>Heating (EN 14511 values)</b>										
Heating capacity (W 10°C/W 45°C)	(3)(9)	kW	43,5	50,3	54,8	64,1	75,3	85,8	95,6	112,3
COP	(3)(9)		4,34	4,45	4,47	4,62	4,71	4,8	4,8	4,71
Efficiency class			B	A	A	A	A	A	A	A
<b>Compressor</b>										
Quantity/Cooling circuits		n°/n°	2 / 1	2 / 1	2 / 1	2 / 1	2 / 1	2 / 1	2 / 1	2 / 1
<b>Pump on the plant side</b>										
Pump head rating	(6)	kPa	101	86	73	151	135	125	120	103
Heat exchanger pressure drop	(4)	kPa	19	24	23	24	28	29	29	38
Heat exchanger pressure drop	(5)	kPa	16	21	20	21	24	25	25	33
Heat exchanger pressure drop	(2)	kPa	21	28	26	27	30	31	34	41
Heat exchanger pressure drop	(3)	kPa	12	15	15	16	17	18	19	25
<b>Pump on the source side</b>										
Pump head rating	(6)	kPa	89	60	40	109	130	117	109	76
Heat exchanger pressure drop	(4)	kPa	33	41	41	42	48	50	50	64
Heat exchanger pressure drop	(5)	kPa	26	33	33	34	39	40	40	52
Heat exchanger pressure drop	(2)	kPa	29	38	36	38	44	47	44	53
Heat exchanger pressure drop	(3)	kPa	17	21	22	22	26	27	26	34
<b>Noise levels</b>										
Noise power level	(7)	dB(A)	63	63	64	64	64	65	65	65
Noise pressure level	(8)	dB(A)	58	58	59	59	59	60	60	60

(1) Total power absorbed by the compressors  
 (2) Ambient water user side input-output 30/35 ° C, input-output water temperature source side 10/7 ° C  
 (3) Temperature input-output water user side 40/45 ° C, input-output water temperature source side 10/7 ° C  
 (4) Temperature input-output water user side 23/18 ° C temperature source side water inlet-outlet 30/35 ° C  
 (5) Temperature input-output water user side 12/7 ° C temperature source side water inlet-outlet 30/35 ° C  
 (6) If provided by the configuration  
 (7) Noise power levels calculated according to ISO 3744, nominal conditions

(8) Noise pressure levels measured at 1 meter from the unit in free field, with a directivity factor Q=4  
 (9) Values according to EN 14511-3:2011

This data sheet gives the characteristic data of the basic and standard versions of the range; for more details please refer to the specific documentation. The values and images inside the document are indicative and can be modified by the manufacturer without prior notification. For further information refer to the specific documentation. The reproduction of this material, even partial, is prohibited.

## CORE & CORE MAX - DIMENSIONS AND OPERATING LIMITS

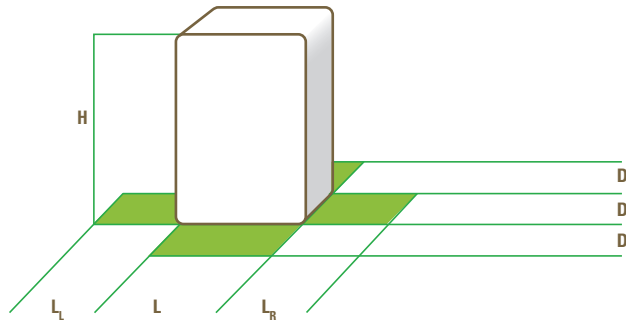

BASIC VERSION				27 ÷ 37	43 ÷ 111
L	Length		mm	890	1.200
D	Depth		mm	760	1.040
H	Height		mm	1.235	1.305
W	Operating weight	(1)	kg	251 ÷ 259	280 ÷ 410

BASIC VERSION				27 ÷ 37	43 ÷ 111
LL	Left side	(2)	mm	500	500
LR	Right side	(2)	mm	500	500
DF	Front side	(2)	mm	500	500
DR	Rear side	(2)	mm	0	0

(1)The weight is only indicative and may vary depending on the unit outfit

(2)The clearance areas are indicated considering that the unit is controlled from the front side. The water connections are always on the upper side of the unit

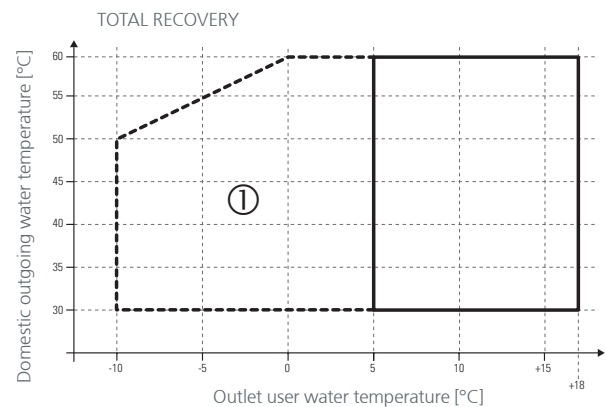
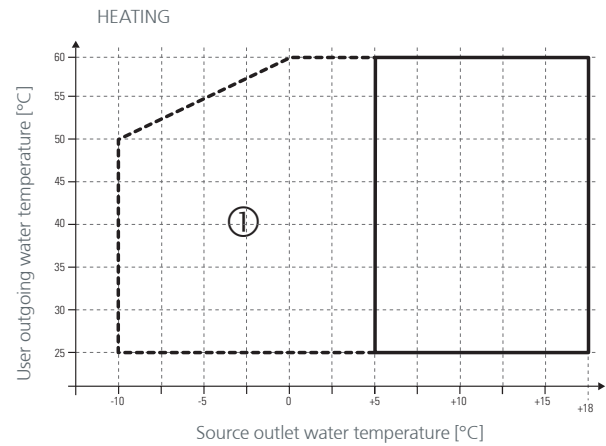
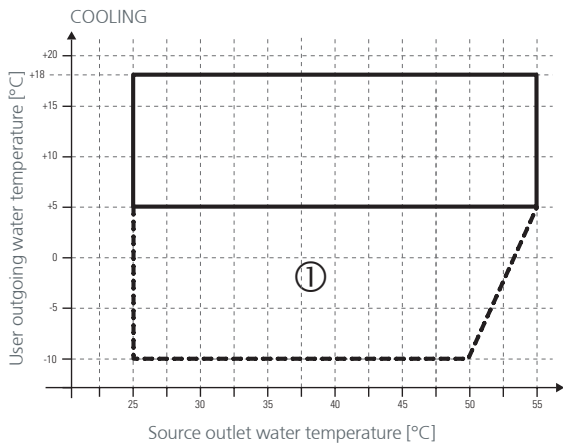

The heat exchanger maximum allowed temperature rise is of 5 °C  
 Ⓛ within this range the unit can operate only with glycol solution on evaporator side

## CORE & CORE MAX - ELECTRICAL DATA

BASIC VERSION			27	32	37	43	50	55	63	74	84	95	111
Maximum absorbed power	(1)	<b>KW</b>	9,1	10,1	11,9	14,6	16,6	18,2	20,2	23,8	27	29,2	33,8
Maximum absorbed current	(2)	<b>A</b>	16	21	22	30	30	32	42	44	50	62	68
Maximum input current	(3)	<b>A</b>	95	111	118	90	116	111	132	140	143	171	208

POMPE	(4)		27	32	37	43	50	55	63	74	84	95	111
<b>Pump on the source side</b>													
Nominal power		<b>W</b>	500	500	500	550	550	550	1100	1100	1100	1100	1100
Nominal current		<b>A</b>	3,46	3,46	3,46	1,58	1,58	1,58	2,7	2,7	2,7	2,7	2,7
<b>Pump on the plant side</b>													
Nominal power		<b>W</b>	190	190	500	550	550	550	1100	1100	1100	1100	1100
Nominal current		<b>A</b>	1,3	1,3	3,46	1,58	1,58	1,58	2,7	2,7	2,7	2,7	2,7
<b>Pump on the domestic water side</b>													
Nominal power		<b>W</b>	190	190	500	550	550	550	1100	1100	1100	1100	1100
Nominal current		<b>A</b>	1,3	1,3	3,46	1,58	1,58	1,58	2,7	2,7	2,7	2,7	2,7

ELECTRICAL POWER SUPPLY	(4)		27	32	37	43	50	55	63	74	84	95	111
Standard power supply		<b>V/ph/Hz</b>	400/3N~/50				400/3~/50						

The indicated data is valid for unit with standard power supply

(1)Electrical power that must be supplied by the mains to power the unit

(2)Internal breakers tripping current. This value is never exceeded and must be used to size the line and its protections (refer to the electric diagram supplied with the unit).

(3)The maximum peak of the current is calculated considering the compressor start and the maximum power absorbed by all the other devices. The value between parenthesis refers to the units equipped with soft-starter (optional).

(4)To be asked for when ordering

The values and images inside the document are indicative and can be modified by the manufacturer without prior notification. For further information refer to the specific documentation. The reproduction of this material, even partial, is prohibited.

CORE & CORE MAX - PUMP DIAGRAMS

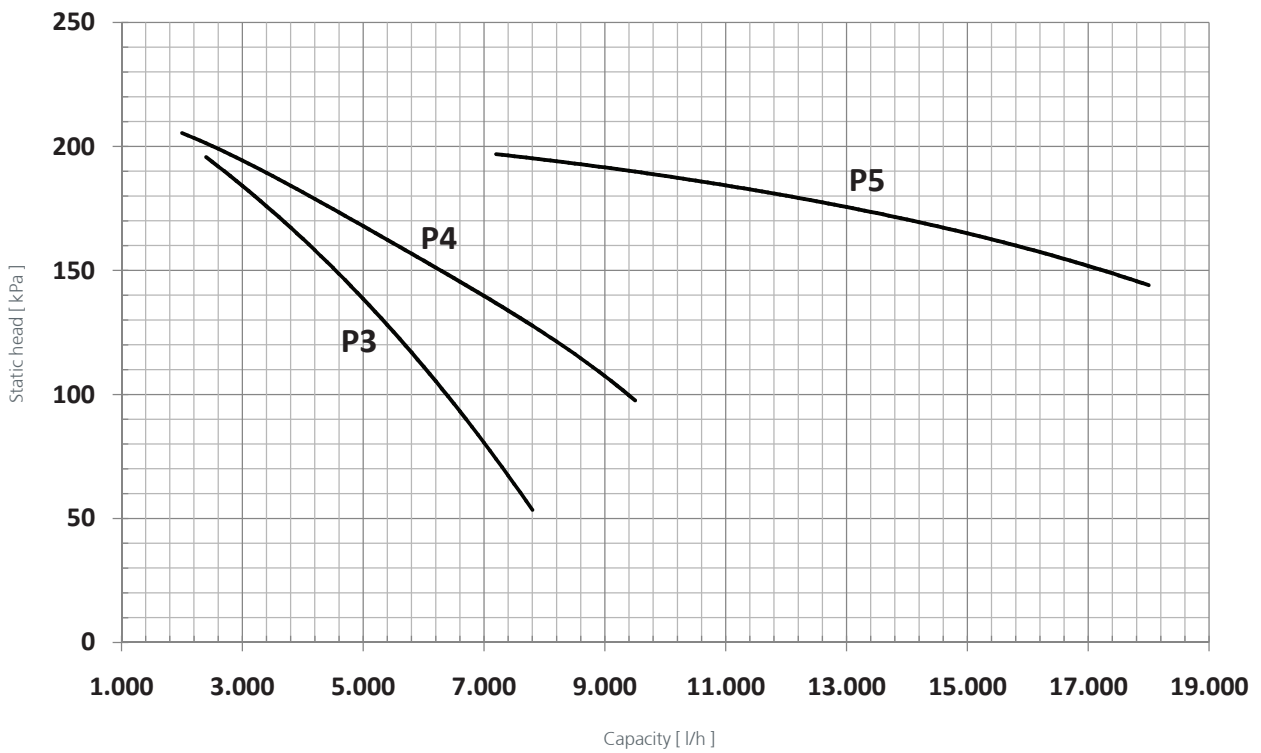
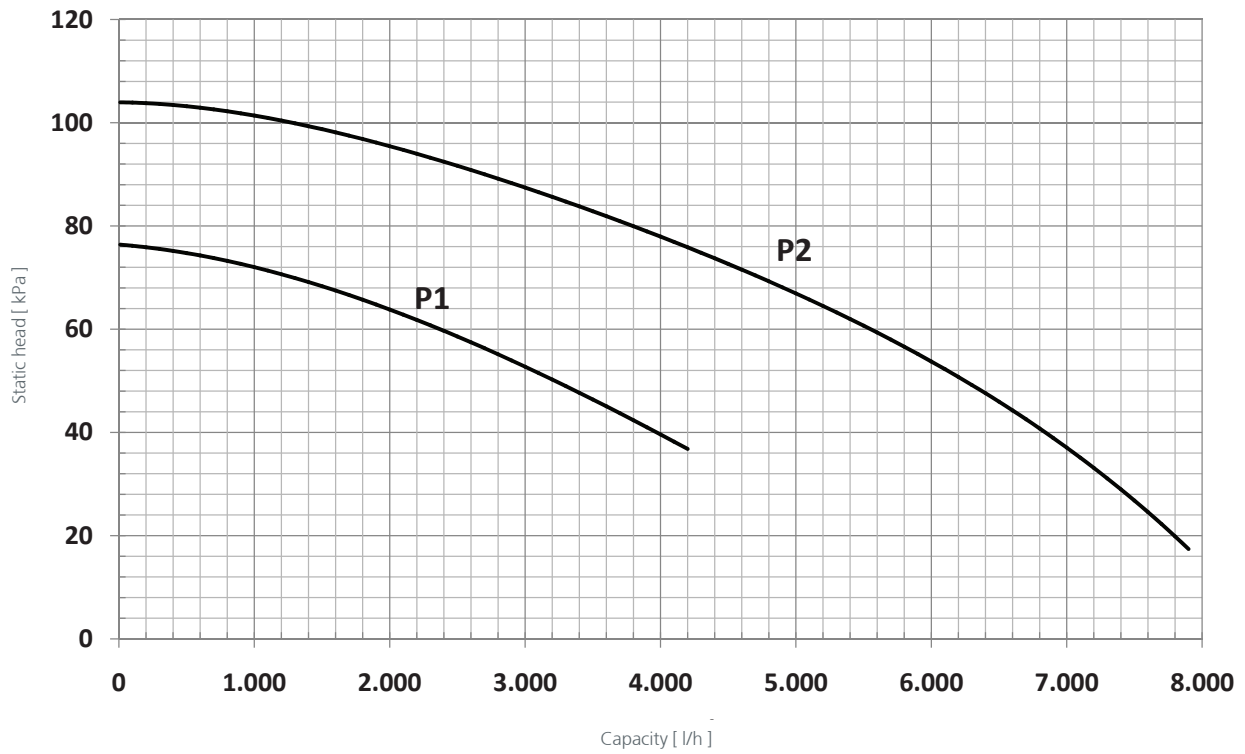

## CORE & CORE MAX - HEAT EXCHANGERS DIAGRAM

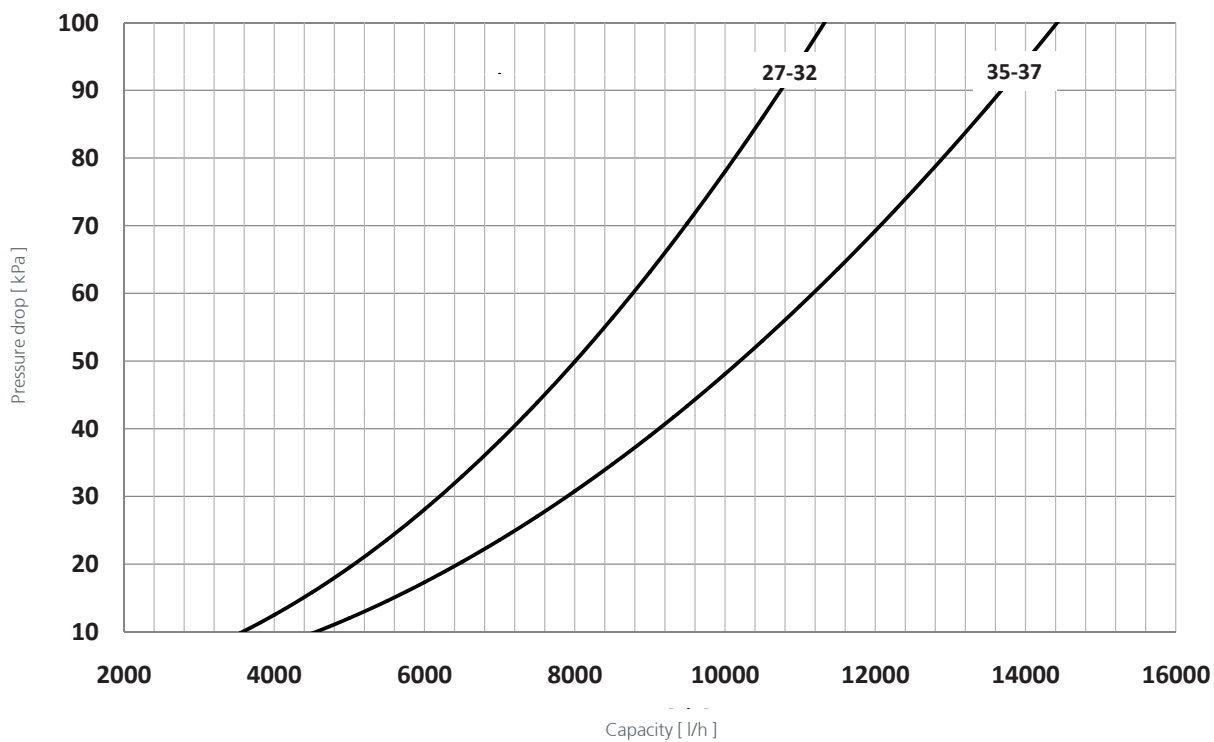

### CORE & CORE MAX - HEAT EXCHANGERS DIAGRAM

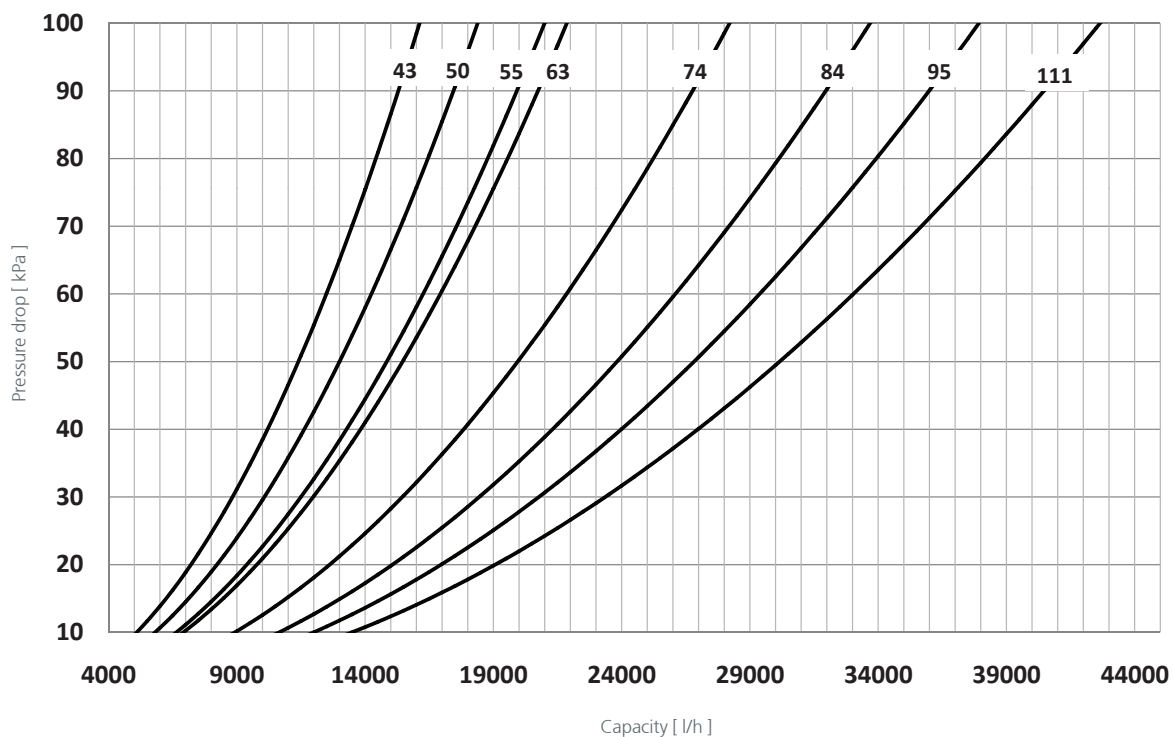



## CORE &amp; CORE MAX - ECODESIGN

Unit size			27	32	37
<b>REGULATION 2013/813</b>					
P <sub>design</sub>		<b>kW</b>	29,6	33,9	40,1
Compliance			Y	Y	Y
$\eta_{sh}$ LT		<b>%</b>	209,5	211,2	222,8
SCOP LT			5,44	5,48	5,77

Unit size			43	50	55	63	74	84	95	111
<b>REGULATION 2013/813</b>										
P <sub>design</sub>		<b>kW</b>	46	53,2	58,1	67,8	79,8	90,9	101,6	118,9
Compliance			Y	Y	Y	Y	Y	Y	Y	Y
$\eta_{sh}$ LT		<b>%</b>	230,2	236	231,5	243,7	249,7	254,6	247,1	239,3
SCOP LT			5,96	6,1	5,99	6,29	6,44	6,57	6,38	6,18

Y = unit compliant to Ecodesign at given conditions.

(2) Water inlet-outlet temperature on user side 30/35 °C, climate profile Average, with reference to regulation 2013/813 and EN 14825.

(3) Core & Core Max are exempted from SCOP MT.

# DIMENSIONAL DRAWING

## CORE ; CORE HWS 27 - 37

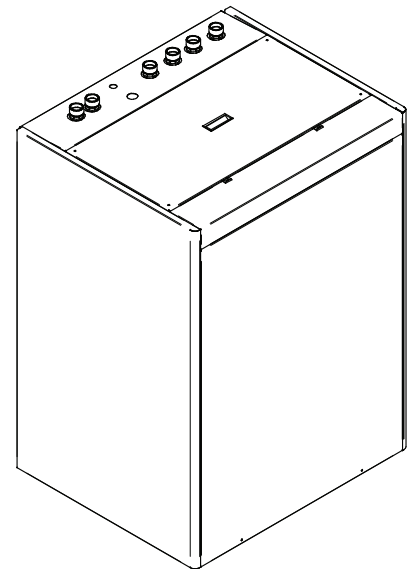
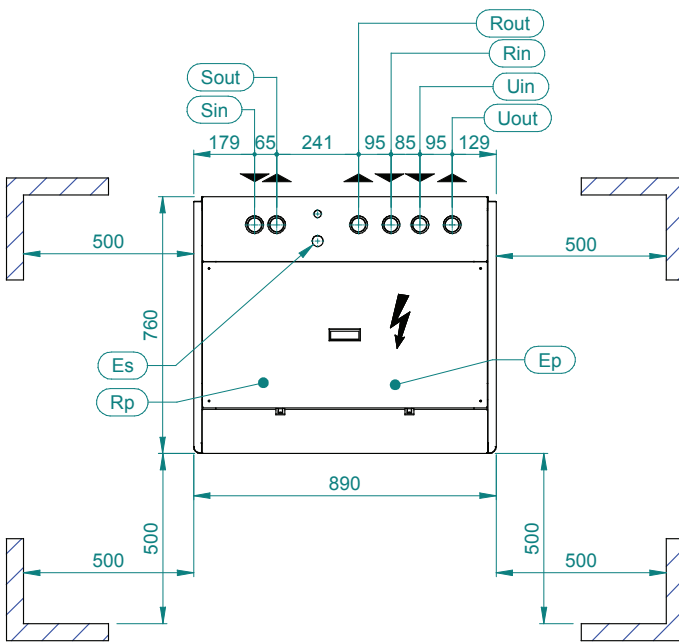
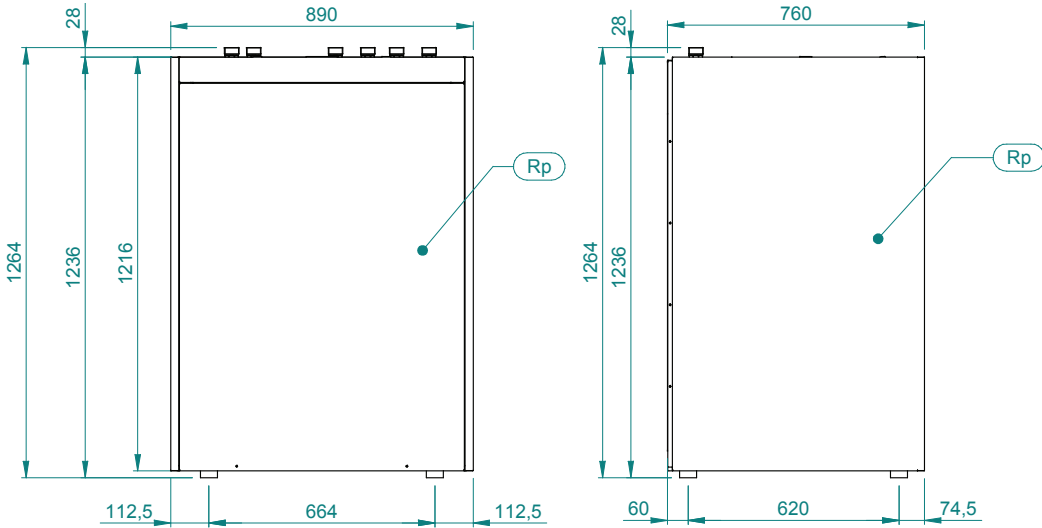

	Rin	Rout	Uin	Uout	Sin	Sout
27-37	G 1" 1/4 F	G 1" 1/4 F	G 1" 1/4 F	G 1" 1/4 F	G 1" 1/4 F	G 1" 1/4 F

Ep	QUADRO ELETTRICO ELECTRICAL PANEL
----	--------------------------------------

Es	INGRESSO ALIMENTAZIONE ELETTRICA ELECTRICAL SUPPLY INLET
----	---

Rp	PANNELLO ASPORTABILE REMOVABLE PANEL
----	---

	SPAZI DI INSTALLAZIONE CLEARANCES
--	--------------------------------------

Rin	INGRESSO ACQUA RECUPERO RECOVERY WATER INLET
-----	---

Rout	USCITA ACQUA RECUPERO RECOVERY WATER OUTLET
------	--

Uin	INGRESSO ACQUA UTILIZZO USER WATER INLET
-----	---

Uout	USCITA ACQUA UTILIZZO USER WATER OUTLET
------	--

Sin	INGRESSO ACQUA SONDE BRINE WATER INLET
-----	---

Sout	USCITA ACQUA SONDE BRINE WATER OUTLET
------	--

## DIMENSIONAL DRAWING

CORE ; CORE HWS 27 - 37

IMPRONTA A TERRA / FOOT PRINT

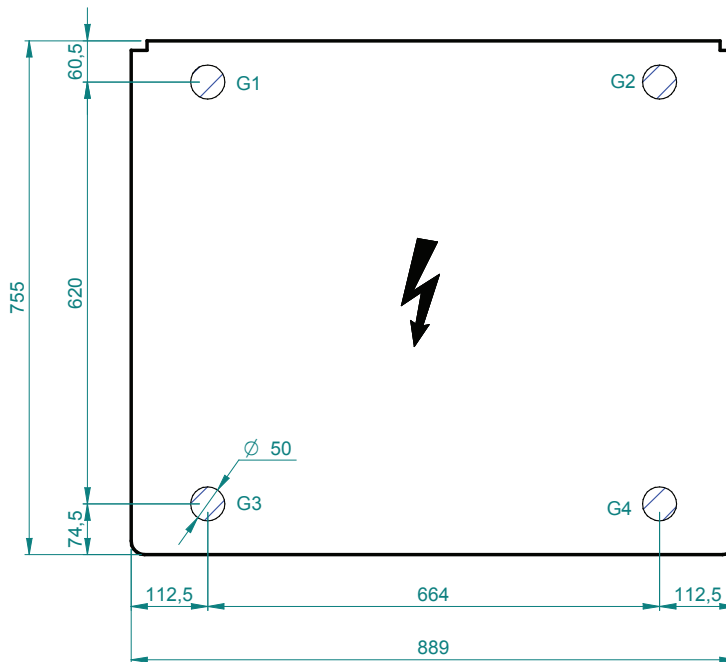

G..	PUNTI DI APPOGGIO ANTIVIBRANTI
	VIBRATION DAMPER FOOT HOLDS

MODELLO MODEL	PESO WEIGHT (Kg)	PESO IN FUNZIONE OPERATING WEIGHT (Kg)	G1	G2	G3	G4
27	251	261	75	75	50	50
32	255	265	77	77	51	51
37	259	269	78	78	52	52

SD00056B

# DIMENSIONAL DRAWING

## CORE MAX ; CORE MAX HWS 43 - 111

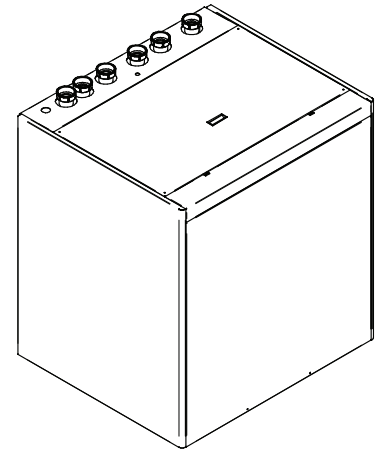
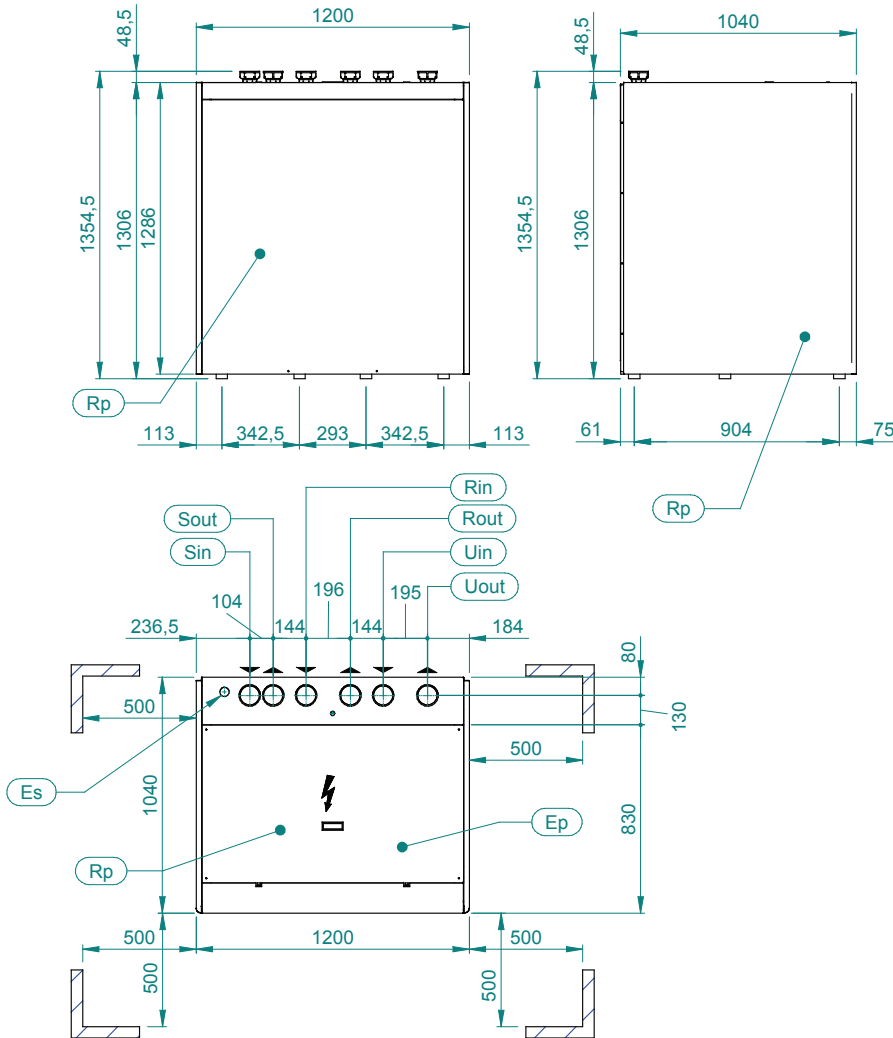

MODELLO MODEL	Rin	Rout	Uin	Uout	Sin	Sout
43-55	G 1" 1/2 F	G 1" 1/2 F	G 1" 1/2 F	G 1" 1/2 F	G 1" 1/2 F	G 1" 1/2 F
63-84	G 2" F	G 2" F	G 2" F	G 2" F	G 2" F	G 2" F
95-111	G 2" 1/2 F	G 2" 1/2 F	G 2" 1/2 F	G 2" 1/2 F	G 2" 1/2 F	G 2" 1/2 F

Ep	QUADRO ELETTRICO ELECTRICAL PANEL
----	--------------------------------------

Es	INGRESSO ALIMENTAZIONE ELETTRICA ELECTRICAL SUPPLY INLET
----	---

Rp	PANNELLO ASPORTABILE REMOVABLE PANEL
----	---

	SPAZI DI INSTALLAZIONE CLEARANCES
--	--------------------------------------

Rin	INGRESSO ACQUA RECUPERO RECOVERY WATER INLET
-----	---

Rout	USCITA ACQUA RECUPERO RECOVERY WATER OUTLET
------	--

Uin	INGRESSO ACQUA UTILIZZO USER WATER INLET
-----	---

Uout	USCITA ACQUA UTILIZZO USER WATER OUTLET
------	--

Sin	INGRESSO ACQUA SONDE BRINE WATER INLET
-----	---

Sout	USCITA ACQUA SONDE BRINE WATER OUTLET
------	--

## DIMENSIONAL DRAWING

### CORE MAX ; CORE MAX HWS 43 - 111

IMPRONTA A TERRA / FOOT PRINT

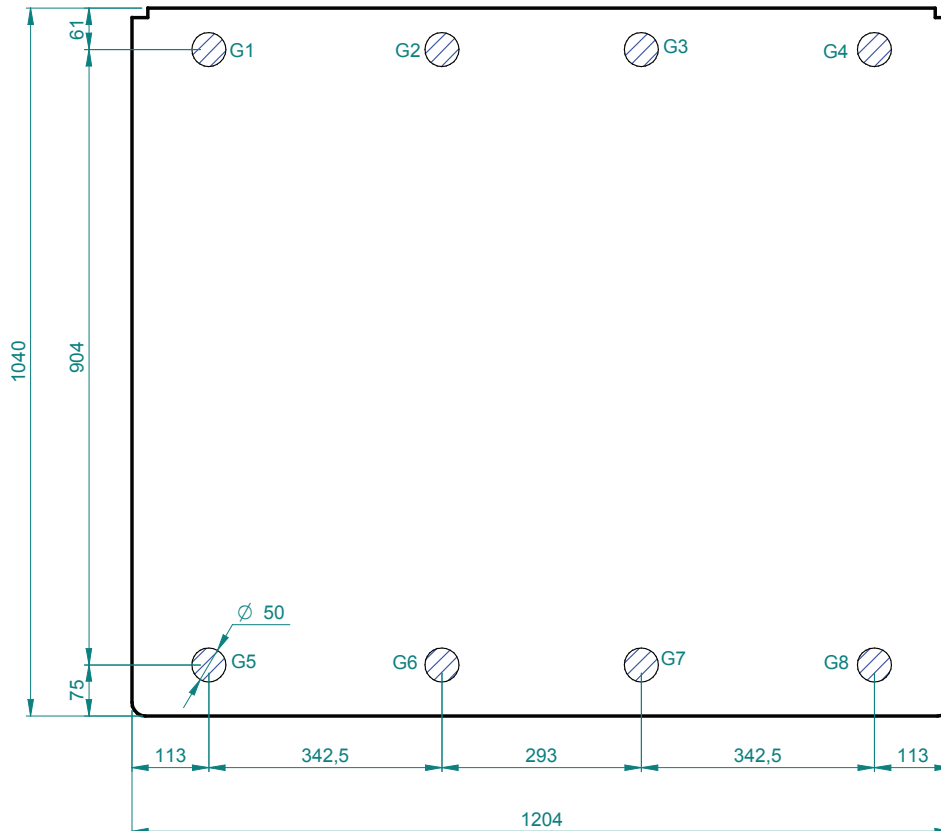

G..	PUNTI DI APPOGGIO ANTIVIBRANTI
	VIBRATION DAMPER FOOT HOLDS

MODELLO MODEL	PESO WEIGHT (Kg)	PESO IN FUNZIONE OPERATING WEIGHT (Kg)	G1	G2	G3	G4	G5	G6	G7	G8
43	280	294	47	46	47	47	24	23	23	23
50	295	310	49	50	49	49	24	24	25	25
55	320	336	54	53	54	53	26	27	26	27
63	335	352	56	54	56	56	28	28	29	28
74	356	374	59	60	60	59	30	32	29	27
84	375	394	63	63	62	61	30	33	29	34
95	380	399	64	63	63	62	31	33	30	34
111	410	431	69	66	68	65	34	35	35	38

SD00057C

## INSTALLATIONS RECOMMENDATIONS

### LOCATION

Strictly allow clearances as indicated in the catalogue.

Please check that there isn't any obstructions on the suction of the finned coil and on the discharge of the fans

Locate the unit in order to be compatible with environmental requirements (sound level, integration into the site, etc.).

### ELECTRICAL CONNECTIONS

Check the wiring diagram enclosed with the unit, in which are always present all the instructions necessary to the electrical connections.

Supply the unit at least 12 hours before start-up, in order to turn crankcase heaters on. Do not disconnect electrical supply during temporary stop periods (i.e. weekends).

Before opening the main switch, stop the unit by acting on the suitable running switches or, if lacking, on the remote control.

Before servicing the inner components, disconnect electrical supply by opening the main switch.

The electric supply line must be equipped with an automatic circuit breaker (to be provided by the installer).

### HYDRAULIC CONNECTIONS

Carefully vent the system, with pump turned off, by acting on the vent valves. This procedure is fundamental: little air bubbles can freeze the evaporator causing the general failure of the system.

Drain the system during seasonal stops (wintertime) or use proper mixtures with low freezing point. In case of temporary stop periods an electric heater should be installed on the evaporator and hydraulic circuit.

Install the hydraulic circuit including all the components indicated in the recommended hydraulic circuit diagrams (expansion vessel, flow switch, strainer, storage tank, vent valves, shut off valves, flexible connections, etc.).

Connect the flow switch, which is furnished on all units, not fitted. Follow the instructions enclosed with the units.

### START UP AND MAINTENANCE OPERATIONS

Strictly follow what reported in use and maintenance manual. All these operations must be carried on by trained personnel only.



**Swegon Operations s.r.l.**

Via Valletta, 5 - 30010

Cantarana di Cona, (VE) Italy - T. +39 0426 921111 - F. +39 0426 302222

[www.blueboxcooling.com](http://www.blueboxcooling.com) - [info@swegon.it](mailto:info@swegon.it)

Swegon Operations s.r.l. a socio unico - P.IVA 02481290282

Società soggetta all'attività di direzione e coordinamento da parte della Investment Latour Svezia

